

TOUGH LOCK™ Consumable Series

Quick Specs	Applications	Series Components	Compatible With	Wire Size
	Automotive Fabrication Manufacturing	Retaining Heads Contact Tips Nozzles	TOUGH GUN™ Robotic MIG Guns TOUGH GUN™ Automatic MIG Guns Bernard™ BTB Semi-Automatic MIG Guns Bernard TGX™ Semi-Automatic MIG Guns Bernard Clean Air™ Fume Extraction Guns	0.023" to 1/8" (0.6 to 3.2 mm)

TOUGH LOCK™ Consumable Series can help to reduce your consumable costs and maintenance downtime.

TOUGH LOCK Retaining Heads, when mated with TOUGH LOCK Contact Tips, minimize contact tip temperature due to increased surface contact.

TOUGH LOCK Contact Tips are manufactured from high-quality, high-conductivity copper using a mandrel-drawn process that controls tip tolerances.

Tregaskiss™ Nozzles
Tregaskiss Insulated Nozzles for MIG welding guns are engineered to be extremely durable and long-lasting. Made of hard-drawn copper or brass, the smooth surface finish and rounded edges minimize weld spatter build-up.

TOUGH LOCK Problem Solvers:

- SURESTART™ Contact Tips
- TOUGH ACCESS™ Series
- TIGHT RADIUS™ System

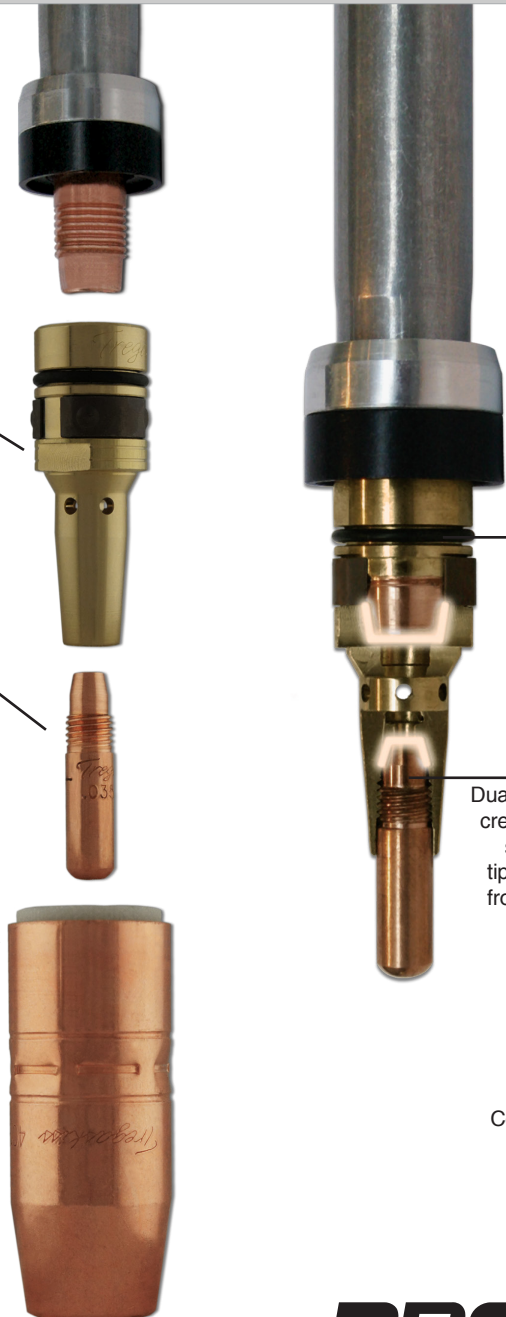

Greater surface area contact between tip, retaining head and neck maximizes heat dissipation.

Dual Taper Technology creates a more secure seat, preventing the tip and retaining head from loosening due to vibration

Cooler tip temperature reduces wear and extends tip life



BETTER HEAT DISSIPATION
Dual Taper Technology keeps consumables running cooler



LOCKED IN TIP TO NECK
Locking feature prevents tip and retaining head from loosening due to vibration

PROLINE
professional welding supplies

Standard Duty (SD) TOUGH LOCK Series

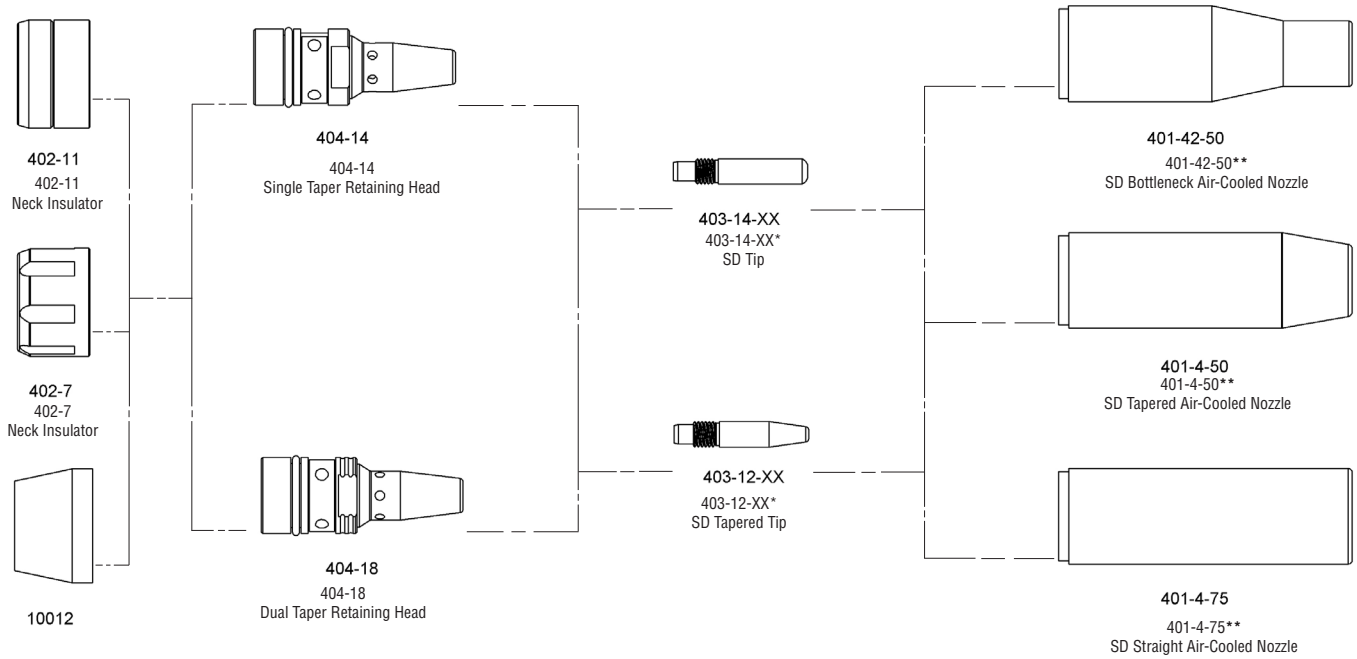

* XX = wire size, see Contact Tip information starting on page 3

Heavy Duty (HD) TOUGH LOCK Series

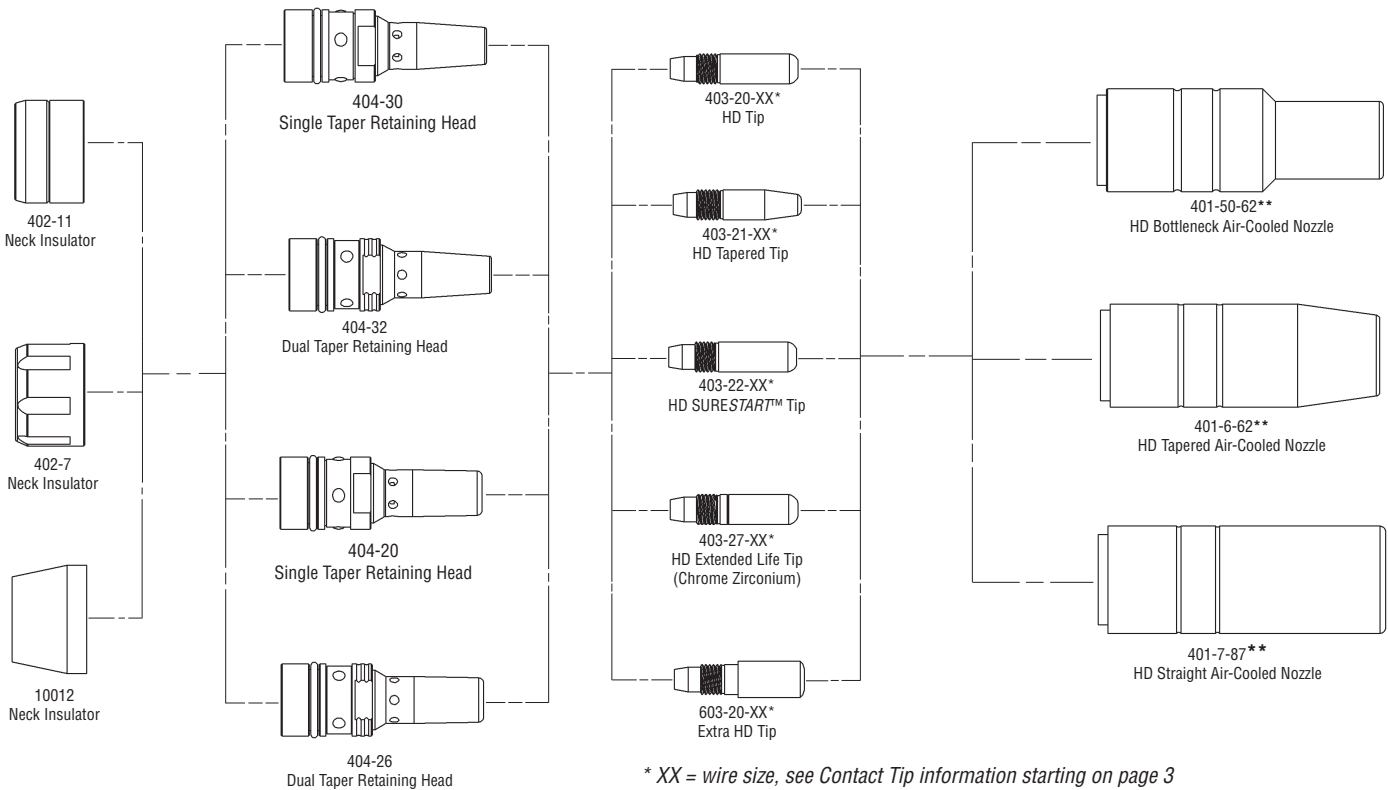

* XX = wire size, see Contact Tip information starting on page 3

**Additional nozzles are available with various stickouts, see pages 4 & 5 for options

Retaining Heads/Diffusers - For Robotic Applications

Part Number	Description	Qty	Duty	Nozzle Type	Material	Platform	Notes
404-14-25	Retaining Head	25	SD	Slip-On	Brass	A/C	Single taper SD retaining head
404-18*	Dual Taper Retaining Head	100	SD	Slip-On	Brass	A/C	Dual taper SD retaining head
404-22*	Retaining Head	100	HD	Slip-On	Brass	A/C	Single taper, set screw for liner retention
404-23-25	Retaining Head	25	HD	Slip-On	Brass	A/C	Single taper, no gas holes. Gasless Flux-Core
404-30*	Retaining Head	100	HD	Slip-On	Brass	A/C	Single taper robotic retaining head
404-32*	Dual Taper Retaining Head	100	HD	Slip-On	Brass	A/C	Standard robotic dual taper retaining head
404-36-25	Retaining Head	25	HD	Slip-On	Copper	A/C	Single taper robotic retaining head
404-50-25	TOUGH ACCESS Retaining Head	25	HD	Slip-On	Brass	A/C	TOUGH ACCESS HD retaining head, to be used with 404-17 neck insulator
404-52-25	Dual Taper Retaining Head	25	HD	Thread-On	Brass	A/C	Standard thread on robotic retaining head
404-54-25	TOUGH ACCESS Retaining Head	25	SD	Slip-On	Brass	A/C	TOUGH ACCESS SD retaining head, to be used with 404-17 neck insulator
404-61-25	TIGHT RADIUS Retaining Head	25	HD	Slip-On	Brass	A/C	Use with TIGHT RADIUS nozzles, 404-62 tip holder & 402-27-02 neck insulator.
404-71	Diffuser	25	HD	Thread-On	Copper	W/C	Diffuser for 600 amp TOUGH GUN Robotic Water-Cooled MIG Gun

Retaining Heads/Diffusers - For Semi-Automatic Applications

Part Number	Description	Qty	Duty	Nozzle Type	Material	Platform	Notes
154-14	Retaining Head	25	SD	Slip-On	Brass	A/C	Single Taper SD retaining head used on 18 amp TGX guns
404-14-25	Retaining Head	25	SD	Slip-On	Brass	A/C	Single taper SD retaining head
404-20*	Retaining Head	100	HD	Slip-On	Brass	A/C	Single taper HD retaining head
404-26*	Dual Taper Retaining Head	100	HD	Slip-On	Brass	A/C	Standard dual taper retaining head
404-38-25	Diffuser	25	HD	Thread-On	Copper	W/C	Used on 62 & 64 series guns with 601 series nozzles & 601-5-75-3 ceramic insulator
404-44*	Retaining Head	100	HD	Slip-On	Brass	A/C	Bernard legacy neck conversion retaining head
404-53-25	Dual Taper Retaining Head	25	HD	Thread-On	Brass	A/C	Standard thread on semi-automatic retaining head

* Other quantities available, contact Customer Service for more information.
 Note: Air-Cooled (A/C) and Water-Cooled (W/C)

TOUGH LOCK Contact Tips

Standard Duty (SD) Tips

0.250" Outside Diameter (O.D.)

Part Number	Description	Qty
403-14-23-25	for 0.023" (0.6 mm)	25
403-14-30*	for 0.030" (0.8 mm)	100
403-14-35*	for 0.035" (0.9 mm)	100
403-14-1.0*	for 0.040" (1.0 mm)	100

SD Tapered Tips (0.250" O.D.)

403-12-30-25	for 0.030" (0.8 mm)	25
403-12-35-25	for 0.035" (0.9 mm)	25
403-12-45-25	for 0.045" (1.2 mm)	25
403-12-52-25	for 0.052" (1.4 mm)	25

Extended Life Tips (0.310" O.D.) (Chrome Zirconium)

403-27-30*	for 0.030" (0.8 mm)	100
403-27-35*	for 0.035" (0.9 mm)	100
403-27-1.0*	for 0.040" (1.0 mm)	100
403-27-45*	for 0.045" (1.2 mm)	100
403-27-364*	for 3/64" (1.2 mm)	100
403-27-52*	or 0.052" (1.3mm)	100

Heavy Duty (HD) Tips (0.310" O.D.)

403-20-30*	for 0.030" (0.8 mm)	100
403-20-35*	for 0.035" (0.9 mm)	100
403-20-1.0*	for 0.040" (1.0 mm)	100
403-20-45*	for 0.045" (1.2 mm)	100
403-20-364*	for 3/64" (1.2 mm)	100
403-20-52*	for 0.052" (1.3 mm)	100
403-20-1.4*	for 0.055" (1.4 mm)	100
403-20-116*	for 1/16" (1.6 mm)	100
403-20-1.8*	for 0.070" (1.8 mm)	100
403-20-78*	for 0.078" (2.0 mm)	100
403-20-564*	for 5/64" (2.0 mm)	100
403-20-332*	for 3/32" (2.4 mm)	100

HD Tapered Tips (0.310" O.D.)

403-21-30*	for 0.030" (0.8 mm)	100
403-21-35*	for 0.035" (0.9 mm)	100
403-21-1.0*	for 0.040" (1.0 mm)	100
403-21-45*	for 0.045" (1.2 mm)	100
403-21-52*	for 0.052" (1.3 mm)	100
403-21-116*	for 1/16" (1.6 mm)	100

Extra Heavy Duty Tips (0.375" O.D.)

603-20-1.0-25	or 0.040" (1.0 mm)	25
603-20-45-25	for 0.045" (1.2 mm)	25
603-20-364-25	for 3/64" (1.2 mm)	25
603-20-52-25	for 0.052" (1.3 mm)	25
603-20-1.4-25	for 0.055" (1.4 mm)	25
603-20-116-25	for 1/16" (1.6 mm)	25
603-20-564-25	for 5/64" (2.0 mm)	25
603-20-332-25	for 3/32" (2.4 mm)	25
603-20-764-25	for 7/64" (2.8 mm)	25
603-20-18-25	for 1/8" (3.2 mm)	25

TOUGH LOCK Teach Tips (0.310" O.D.) (for robotic programming)

403-20-01	Adjustable Teach Tip	1
403-20-05	Teach Tip 1/2"	1
403-20-062	Teach Tip 5/8"	1
403-20-075	Teach Tip 3/4"	1
403-20-10mm	Teach Tip 10 mm	1
403-20-15mm	Teach Tip 15 mm	1

SURESTART™ Contact Tips

Prevent early, unexpected burn-backs and reduce arc start failures by up to 50%* by using SURESTART Contact Tips on your MIG welding guns.

These contact tips are especially beneficial for applications with a high volume of tracking and short welds using solid wire in CV (Constant Voltage) welding modes. Blister packaging protects tips from harmful welding environments and makes it suitable for use in vending machines.

*Results based on customer field tests and Tregaskiss R&D lab tests

Heavy Duty Tips (0.310" O.D.)

403-22-30	for 0.030" (0.8 mm)
403-22-35	for 0.035" (0.9 mm)
403-22-1.0	for 0.040" (1.0 mm)
403-22-45	for 0.045" (1.2 mm)
403-22-364	for 3/64" (1.2 mm)
403-22-52	for 0.052" (1.3 mm)

Heavy Duty Tapered Tips (0.310" O.D.)

403-23-30	for 0.030" (0.8 mm)
------------------	---------------------



Available in packages of 20 contact tips

Nozzles

Tregaskiss Nozzles feature:

- High-temperature resistant fiberglass insulators which electrically insulate the nozzle from the diffuser
- Heavy duty crimp holds all three layers together
- Available in slip-on and thread-on styles



Bottleneck



Straight



Taper

Light Duty Air-Cooled Nozzles (Slip-On)

For use with TOUGH LOCK™ Diffuser 154-14

Part Number	Bore	Tip Placement	Type	Material	O.D.	Length	Qty
151-1-38	3/8"	1/8" Recess	Taper	Brass	0.813"	2.13"	10
151-1-50	1/2"	1/8" Recess	Taper	Brass	0.813"	2.13"	10
151-50	1/2"	Flush	Taper	Brass	0.813"	2.00"	10

Standard Duty (SD) Air-Cooled Nozzles (Slip-On)

For use with TOUGH LOCK™ Diffuser 404-32 (Robotic) or 404-26 (Semi-Automatic)

Part Number	Bore	Tip Placement	Type	Material	O.D.	Length	Qty	Reamer Cutter Blade
401-40-38	3/8"	1/16" Recess	Taper	Brass	0.978"	2.81"	10	---
401-42-50**	1/2"	1/8" Recess	Bottleneck*	Brass	0.938"	2.88"	10	RCT-04
401-4-38	3/8"	Flush	Taper	Copper	0.938"	2.74"	10	---
401-44-50	1/2"	1/4" Stick-out	Bottleneck*	Brass	0.938"	2.50"	10	RCT-04
401-44-62	5/8"	1/4" Stick-out	Taper	Copper	0.938"	2.51"	10	RCT-01
401-4-50**	1/2"	1/8" Recess	Taper	Copper	0.938"	2.88"	10	RCT-04
401-4-62**	5/8"	1/8" Recess	Taper	Copper	0.938"	2.88"	10	RCT-01
401-4-75	3/4"	1/8" Recess	Straight	Copper	0.938"	2.88"	10	RCT-12
401-48-50	1/2"	1/8" Stick-out	Bottleneck*	Brass	0.938"	2.63"	10	RCT-04
401-8-62	5/8"	1/8" Stick-out	Taper	Copper	0.938"	2.63"	10	RCT-01

*Straight bore; ideal for reaming

Standard Duty Air-Cooled Nozzles (Thread-On)

For use with TOUGH LOCK™ Diffuser 404-52 (Robotic) or 404-53 (Semi-Automatic)

Part Number	Bore	Tip Placement	Type	Material	O.D.	Length	Qty	Reamer Cutter Blade
401-18-62	5/8"	1/8" Stick-out	Taper	Copper	0.938"	2.63"	10	RCT-01
401-42-38	3/8"	1/8" Recess	Taper	Copper	0.938"	2.88"	10	---
401-43-50	1/2"	1/4" Recess	Taper	Copper	0.938"	3.00"	10	RCT-04
401-43-62	5/8"	1/8" Recess	Taper	Copper	0.938"	2.88"	10	RCT-01
401-47-51	1/2"	1/8" Recess	Taper	Copper	0.938"	2.88"	10	RCT-04
401-48-50CT	1/2"	1/8" Stick-out	Taper	Copper	0.938"	2.63"	10	RCT-04

For use with TOUGH LOCK™ Diffuser 404-15

Part Number	Bore	Tip Placement	Type	Material	O.D.	Length	Qty	Reamer Cutter Blade
401-16-50	1/2"	1/8" Stick-out	Taper	Copper	0.938"	2.63"	10	RCT-04
401-45-38	3/8"	Flush	Taper	Copper	0.938"	2.74"	10	---
401-45-50	1/2"	1/8" Recess	Taper	Copper	0.938"	2.88"	10	RCT-04
401-45-62	5/8"	1/8" Recess	Taper	Copper	0.938"	2.88"	10	RCT-01
401-46-38	3/8"	1/8" Recess	Taper	Copper	0.938"	2.88"	10	---
401-46-50	1/2"	1/4" Recess	Taper	Copper	0.938"	3.00"	10	RCT-04
401-46-62	5/8"	1/4" Recess	Taper	Copper	0.938"	3.00"	10	RCT-01
401-47-50	1/2"	1/8" Recess	Bottleneck*	Copper	0.938"	2.88"	10	RCT-04

*Straight bore; ideal for reaming

Heavy Duty (HD) Air-Cooled Nozzles (Slip-On)

For use with TOUGH LOCK™ Diffuser 404-32 (Robotic) or 404-26 (Semi-Automatic)

Part Number	Bore	Tip Placement	Type	Material	O.D.	Length	Qty	Reamer Cutter Blade
401-48-62	5/8"	Flush	Bottleneck*	Copper	1.062"	2.76"	10	RCT-01
401-49-62	5/8"	1/8" Stick-out	Bottleneck*	Copper	1.062"	2.63"	10	RCT-01
401-50-62	5/8"	5 mm Recess	Bottleneck*	Copper	1.062"	2.95"	10	RCT-01
401-51-62	5/8"	Flush	Bottleneck*	Brass	1.062"	2.76"	10	RCT-01
401-5-62**	5/8"	1/4" Recess	Taper	Copper	1.062"	3.00"	10	RCT-01
401-5-75	3/4"	1/4" Recess	Taper	Copper	1.062"	3.00"	10	RCT-12
401-6-50	1/2"	1/8" Recess	Taper	Copper	1.062"	2.88"	10	RCT-04
401-6-62**	5/8"	1/8" Recess	Taper	Copper	1.062"	2.88"	10	RCT-01
401-6-75	3/4"	1/8" Recess	Taper	Copper	1.062"	2.88"	10	RCT-12
401-71-62	5/8"	1/8" Recess	Taper*	Brass	1.106"	2.88"	10	RCT-01
401-72-62	5/8"	1/8" Recess	Taper	Brass	1.062"	2.88"	10	RCT-01
401-7-62	5/8"	1/4" Recess	Taper	Brass	1.106"	3.00"	10	RCT-01
401-7-75	3/4"	1/8" Recess	Taper	Brass	1.106"	2.88"	10	RCT-12
401-7-87	7/8"	1/4" Recess	Straight	Brass	1.106"	3.00"	10	RCT-12***
401-81-62	5/8"	1/8" Stick-out	Taper	Copper	1.062"	2.63"	10	RCT-01
401-87-56	9/16"	1/8" Recess	Taper	Brass	1.062"	2.88"	10	RCT-04***
401-87-62	5/8"	1/8" Stick-out	Taper	Brass	1.062"	2.63"	10	RCT-01
401-88-62	5/8"	Flush	Taper	Brass	1.062"	2.76"	10	RCT-01
401-91-62	5/8"	1/8" Stick-out	Taper*	Brass	1.106"	2.63"	10	RCT-01
401-92-62	5/8"	1/4" Stick-out	Taper	Brass	1.106"	2.50"	10	RCT-01

*Straight bore; ideal for reaming

***May not clean spatter ring inside nozzle bore

Heavy Duty Air-Cooled Nozzles (Thread-On)

For use with TOUGH LOCK™ Diffuser 404-52 (Robotic) or 404-53 (Semi-Automatic)

Part Number	Bore	Tip Placement	Type	Material	O.D.	Length	Qty	Reamer Cutter Blade
401-14-62	5/8"	1/8" Recess	Taper	Copper	1.062"	2.88"	10	RCT-01
401-19-62	5/8"	1/4" Recess	Taper	Brass	1.062"	3.00"	10	RCT-01
401-20-62	5/8"	1/8" Stick-out	Taper	Copper	1.062"	2.63"	10	RCT-01
401-41-62	5/8"	1/8" Stick-out	Taper	Brass	1.062"	2.63"	10	RCT-01
401-41-75	3/4"	1/8" Recess	Taper	Brass	1.062"	2.88"	10	RCT-12
401-52-62	5/8"	1/4" Recess	Taper	Copper	1.062"	3.00"	10	RCT-01
401-53-62	5/8"	1/8" Stick-out	Bottleneck	Copper	1.062"	2.63"	10	RCT-01

Heavy Duty Water-Cooled Nozzles

For use with 600 amp Bernard T-Gun™ Water-Cooled and TOUGH GUN Automatic Water-Cooled MIG Guns

Part Number	Bore	Tip Placement	Type	Material	O.D.	Length	Qty	Reamer Cutter Blade
601-5-62	5/8"	1/4" Recess	Taper	Nickel-Plated Bronze	1.225"	3.13"	10	RCT-01
601-6-62	5/8"	1/8" Recess	Taper	Nickel-Plated Bronze	1.225"	3.00"	10	RCT-01
601-5-75	3/4"	1/4" Recess	Taper	Nickel-Plated Bronze	1.225"	3.13"	10	RCT-12
601-6-75	3/4"	1/8" Recess	Taper	Nickel-Plated Bronze	1.225"	3.00"	10	RCT-12

Use 601-5-75-3 Insulator for all 601 Series Nozzles
Use 404-38 diffuser for all 601 Series Nozzles

Heavy Duty Nozzles for TOUGH GUN™ Robotic Water-Cooled MIG Guns

Part Number	Bore	Tip Placement	Type	Material	O.D.	Length	Qty	Reamer Cutter Blade
650-6-62	5/8"	1/8" Recess	Taper	Chrome	1.062"	3.60"	2	RCT-01
650-6-75	3/4"	1/8" Recess	Taper	Chrome	1.062"	3.60"	2	RCT-12

Use 404-32 Diffuser for all 650 Series Nozzles

TOUGH ACCESS™ Series

TOUGH ACCESS™ Consumables

are a sleek line of consumables (including retaining heads and nozzles) that allow entry into those hard-to-reach places that would otherwise be inaccessible due to fixture design or weldment. Available in straight bore and bottleneck style nozzles, these unique consumables are compatible with TOUGH LOCK™ Contact Tips.

TOUGH ACCESS Nozzles are compatible with:

- TOUGH LOCK™ Contact Tips*
- TOUGH GUN™ Aluminum Armored Necks
- TOUGH GUN™ Reamer

*Standard duty consumables are recommended for bottleneck styles



Nozzles:

Part Number	Bore	Tip Placement	Type	Material	O.D.	Length	Qty	Reamer Cutter Blade
401-54-50	1/2"	1/8" Recess	Bottleneck*	Copper	0.850"	2.400"	10	RCT-05
401-55-50	1/2"	Flush	Bottleneck*	Copper	0.850"	2.275"	10	RCT-05
401-56-50	1/2"	1/8" Stick-Out	Bottleneck*	Copper	0.850"	2.150"	10	RCT-05
401-57-50	1/2"	1/4" Stick-Out	Bottleneck*	Copper	0.850"	2.025"	10	RCT-05
401-54-62	5/8"	1/8" Recess	Straight	Copper	0.850"	2.400"	10	RCT-10
401-55-62	5/8"	Flush	Straight	Copper	0.850"	2.275"	10	RCT-10
401-56-62	5/8"	1/8" Stick-Out	Straight	Copper	0.850"	2.150"	10	RCT-10
401-57-62	5/8"	1/4" Stick-Out	Straight	Copper	0.850"	2.025"	10	RCT-10

*Straight bore; ideal for reaming

NOTE: Must be used with 402-17 Neck Insulator

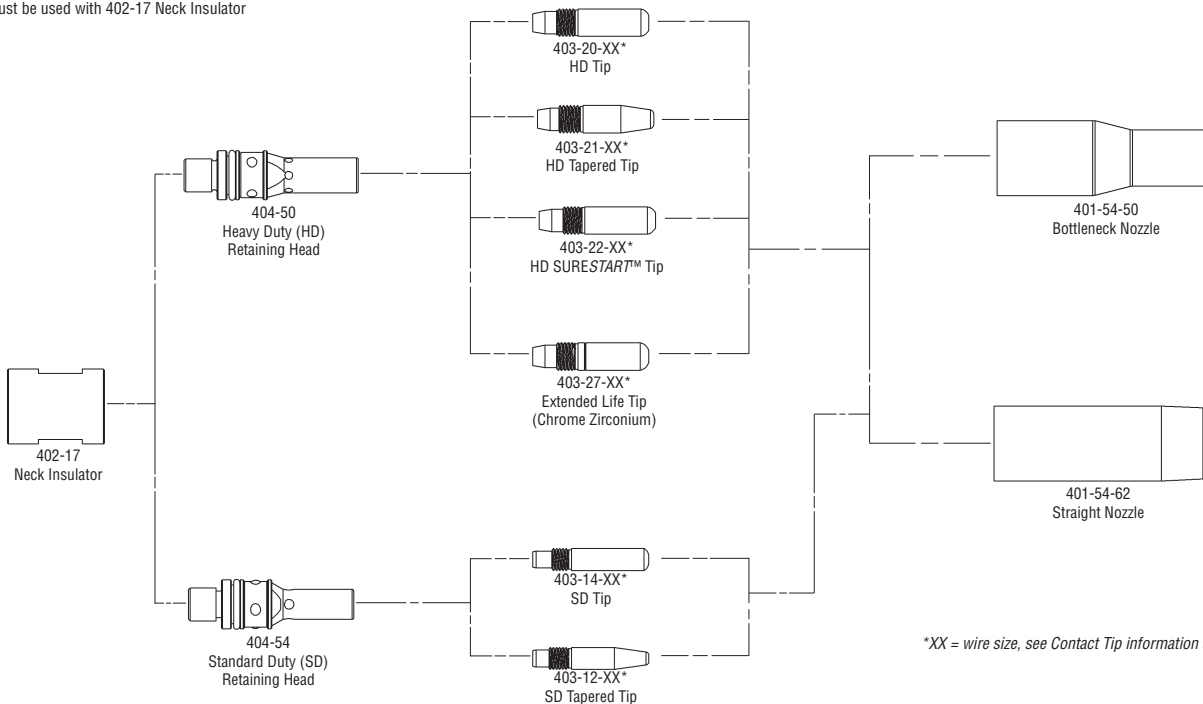

*XX = wire size, see Contact Tip information starting on page 3

TIGHT RADIUS™ System

The **TIGHT RADIUS** System features sleek consumables that allow entry into hard-to-reach places and includes a unique neck, compact slip-on nozzle, retaining head and contact tip holder.

Semi-Automatic Necks (Fixed) Quantity

305-22TR	22° TIGHT RADIUS Neck	1
305-45TR	45° TIGHT RADIUS Neck	1
305-60TR	60° TIGHT RADIUS Neck	1

Quick Change Robotic Necks:

305-22QCTR	22° TIGHT RADIUS Neck	1
305-45QCTR	45° TIGHT RADIUS Neck	1
305-60QCTR	60° TIGHT RADIUS Neck	1

Neck Insulator

402-11* Tregaskiss Neck Insulator **Quantity: 100**

* Other quantities available, contact Customer Service for more information.

Tip Holder:

404-62 TIGHT RADIUS Tip Holder **Quantity: 10**

Retaining Head:

404-61-25 TIGHT RADIUS Heavy Duty Retaining Head **Quantity: 25**

Nozzles:

Part Number	Bore	Tip Placement	Material	O.D.	Length	Qty	Reamer Cutter Blade
401-11-62	5/8"	1/8" Recess	Copper	1.062"	1.552"	10	RCT-01
401-12-50	1/2"	Flush	Copper	1.062"	1.427"	10	RCT-04
401-13-62	5/8"	1/8" Stick-Out	Copper	1.062"	1.302"	10	RCT-01



TIGHT RADIUS System is available for semi-automatic and robotic applications

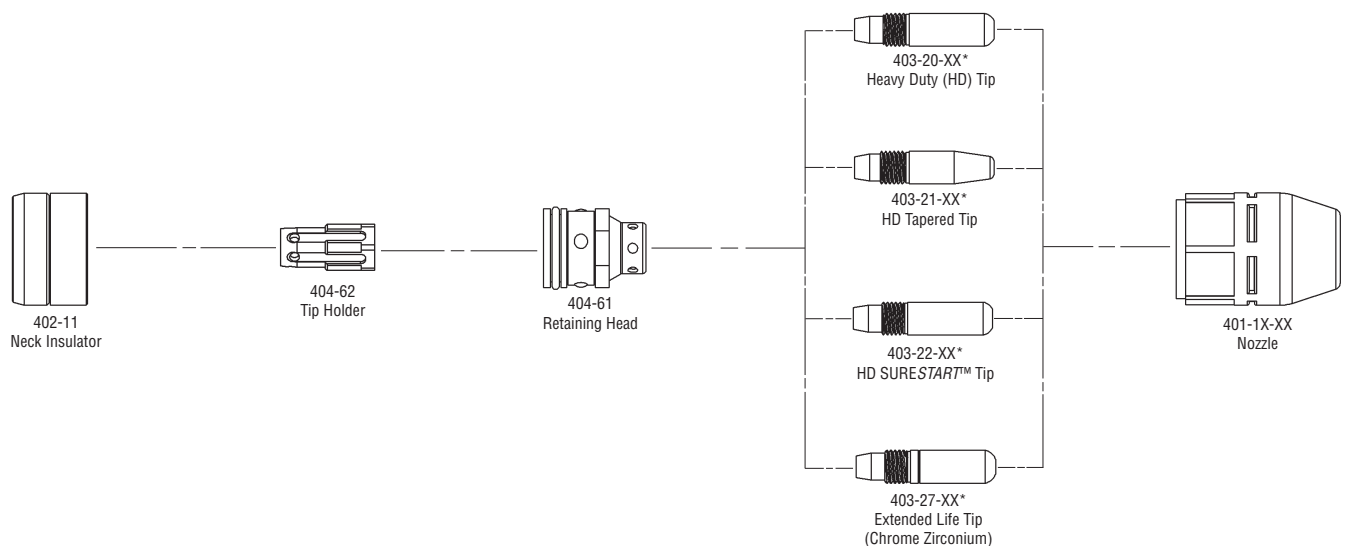

*XX = wire size, see Contact Tip information starting on page 3

TOUGH LOCK™ Conversion Series

Add our TOUGH LOCK Consumables, durable nozzles and neck insulators / adaptors to your Bernard™, Binzel®, Lincoln® and Tweco® style MIG Guns. Find your MIG gun make and model on the left, then follow the chart to the right for parts needed to upgrade.

***NOTE:** The 404-20 TOUGH LOCK Retaining Head will fit on most necks with an external 9/16"-18 thread regardless of angle.

Gun Manufacturer	Gun Model	Gun Neck	TOUGH LOCK Heavy Duty Retaining Head	Neck Insulator	Adaptor
Bernard™	Q-Gun™ Series	Legacy Neck	404-44	402-14	N/A
Binzel®	ALPHA 4	---	404-46	402-11	N/A
Lincoln®	Magnum® 300	KP1929 / KP1928 / KP1941	404-20*	402-14	N/A
	Magnum® 400	KP1929 / KP1928 / KP1941	404-20*	402-14	N/A
Tweco®	Tweco #3	63J-60	404-20*	402-14	N/A
	Tweco #4	64J-60	404-20*	402-14	N/A
	Spray Master™ 350	MS63-60	404-20*	402-14	N/A
	Spray Master™ 450	MS64H-60	404-20*	402-14	N/A
	WeldSkill® 400	64A-60	404-20*	402-14	N/A
	MINI-MIG	---	N/A	402-19	404-64